

UNIVERSITY OF
Waterloo



Department of Mechanical and Mechatronics Engineering

ME100: Hydraulic/Pneumatic Hoist Kit

A Report Prepared For:

ME100 Teaching Team

Prepared By:

Joyce Chen | Emily Folk | Remy Lambert | Lance Pharand

Department of Mechanical and Mechatronics Engineering

University of Waterloo

200 University Ave W.

Waterloo, Ontario, N2L 3G1

17 November 2020

Department of Mechanical and Mechatronics Engineering
University of Waterloo
200 University Ave W.
Waterloo, Ontario, N2L 3G1
17 November 2020

Professors and Teaching Team,

This report, entitled: Hydraulic/Pneumatic Hoist Kit, was prepared as our design project II submission for ME100: Introduction to Mechanical Engineering Practice I. The purpose of this report is to demonstrate and discuss the engineering design concept we have selected for our product, and to outline the progress we have made towards developing this kit.

As students pursuing an education amidst a pandemic, we are passionate about interactive learning and understand its importance in a school setting. The hoist kit was designed to capture the key aspects of science, technology, engineering, and math (STEM) courses in a hands-on manner to which students are less exposed, particularly post-COVID-19. Our prototypes and data display intriguing results and affirm the idea that learning new, challenging concepts can be fun.

Thank you for your time and consideration. If you have any queries or concerns, please contact any one of us.

This report was written entirely by us and has not received any previous academic credit at this or any other institution.

Signed,

Joyce Chen 
joyce.chen1@uwaterloo.ca
1A ME

Emily Folk 
efolk@uwaterloo.ca
1A ME

Remy Lambert 
r4lambert@uwaterloo.ca
1A ME

Lance Pharanand 
l2pharan@uwaterloo.ca
1A ME

Table of Contents

List of Figures	ii
List of Tables	ii
Summary	1
1.0 Introduction.....	2
1.1 Comparable Products	3
1.2 Objective	4
1.3 Theory	5
2.0 Problem Definition.....	7
2.1 Main Functions.....	7
2.1.1 Develop engineering design comprehension	7
2.1.2 Establish an understanding of topics in fluid physics and chemistry	7
2.2 Constraints and Criteria.....	8
2.3 Safety Considerations.....	8
3.0 Technical Progress	9
3.1 Solution and Design Iterations	9
3.2 Kit Components.....	11
3.3 Progress to Date	12
3.3.1 Choosing the liquids for the syringe systems	12
3.3.2 Designing the hoist kit structure	13
3.3.3 Implementing replaceable syringe systems	14
3.3.4 Heating the peanut butter prototype.....	15
3.4 Remaining Challenges.....	15
3.5 Data and Observations	16
3.6 Discussion and Analysis	17
4.0 Conclusions.....	18
4.1 Project Conclusions.....	18
4.2 Future Recommendations.....	18
References.....	19
Appendix.....	20
Appendix A – Hoist Lab Handout.....	20
Appendix B: Equation Derivations	34

List of Figures

Figure 1: Photos of the hoist prototypes: (from left to right: water, peanut butter).....	2
Figure 2: Photos of the hoist prototypes: (from left to right: ketchup, air).....	3
Figure 3: The Elecno Teach Tech HydroBot Arm Kit [2].....	3
Figure 4: Hydraulic Mini Cherry Picker [3]	4
Figure 5: Iterations of the Hoist Arm Design	9
Figure 6: A SolidWorks model of the final hoist design	10
Figure 7: SolidWorks model of the prefabricated base mounts.....	10
Figure 8: A picture of the kit components.	11
Figure 9: The technical drawing of the hoist included in the kit	12
Figure 10: Steps of putting together the base.....	13
Figure 11: The use of paperclips to fasten the syringes.....	14
Figure 12: Photos of the peanut butter prototype.....	15

List of Tables

Table 1: A table of qualitative and quantitative data collected during prototyping.....	16
---	----

Summary

This report outlines the development of the hoist kit through various stages of research, prototyping, and observation. Beginning with comparable products, both complex and simple hydraulic arm demo kits are discussed to highlight how the hoist kit takes into consideration the best aspects of each design while maintaining its individuality. A thorough analysis of four hoist prototypes filled with water, peanut butter, ketchup, and air respectively are provided with quantified results. Syringes were selected as pistons because they mimic piston function accurately but are smaller and cheaper. Fasteners were used to elevate the kit from a craft to a fully equipped mechanism with washers for force distribution and nuts to control the stiffness of the arm. The base of the hoist was developed to demonstrate how intelligent design reduces the need for extra support materials such as tape and glue. Moreover, the substances in each prototype were selected specifically to demonstrate how the results vary significantly due to the different fluid properties. The water-driven hoist behaves ideally, possessing the ability to easily displace an object over a great distance. The air-driven hoist moves quickly, but the compressibility of air prevents full extension of the output piston. This observation, despite being visually apparent, is further proved in the lab following the construction of the hoist. Air compressibility is extremely relevant in industry since it dictates whether a machine should be hydraulic or pneumatic. Ketchup and peanut butter were selected as test substances to show an exaggerated representation of the implications of fluid properties, such as viscosity. The results for ketchup were promising, but the force required to move the peanut butter-powered piston caused the syringe to break. It is a nonviable option because in addition to being a deadly allergen, there is no feasible way to remove the peanut butter and replace it with another substance, which results in a kit that is environmentally wasteful. Steps to mitigate these problems, such as creating a design with replaceable syringes, are motivated by the constraints and criteria. Overall, the cost of material to build one prototype was approximately \$15.00, which is much lower than any comparable product of similar complexity, as seen in the comparable products section. A critical aspect of the kit concept is clarity and intuitive design; it allows for the hoist to be recreated accurately, regardless of whether the students are working on it from home or in a classroom with their peers. Despite the success of the current prototypes, plans for future designs include a device to depress the pistons mechanically so human intervention is not required.

1.0 Introduction

According to a study conducted by Carnegie Mellon University, students are six times more likely to learn better through interactive study in a school environment [1]. This can be achieved through group work and labs at the high school and university level. COVID-19 has made hands-on learning increasingly difficult, leading to a disconnect in the understanding of theoretical and practical material. Challenging courses such as physics and chemistry can seem even more abstruse without live demonstrations or other tangible aids. The hoist kit is designed specifically to bridge this disconnect, whether in school or at home amidst the pandemic. It is the goal of this initiative to establish a firm connection between a design idea and the final product, all while providing a hands on demonstration of fluid dynamics and engineering graphics and design (EGAD) in action, as seen in Figures 1 and 2. This report will outline the approach to achieving the objective, the rationale behind the design, its application to relevant concepts, and potential next steps for improvement.

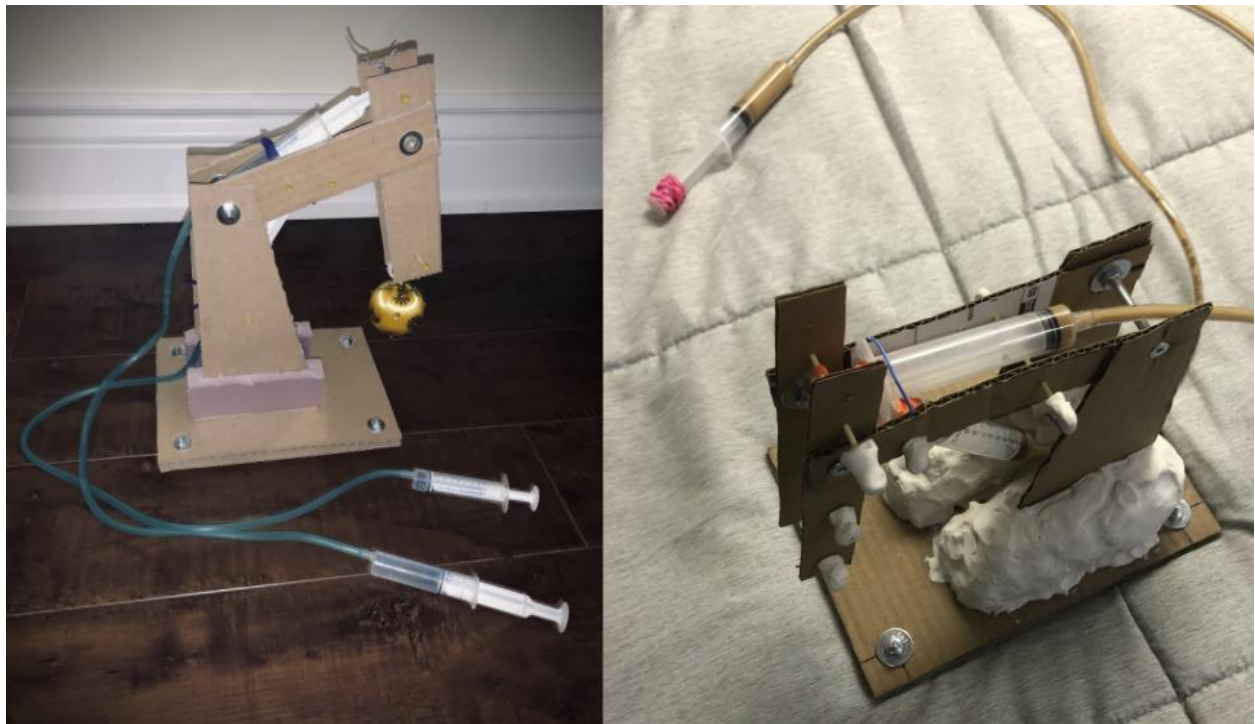

Figure 1: Photos of the hoist prototypes: (from left to right: water, peanut butter)



Figure 2: Photos of the hoist prototypes: (from left to right: ketchup, air)

1.1 Comparable Products

A comparable product of high complexity seen in Figure 3: The Elecnor Teach Tech HydroBot Arm Kit is the *Elecnor Teach Tech HydroBot Arm Kit* sold on Amazon. This kit costs \$77.29 before tax and differs from the one outlined in this report in its assembly and function. Though both kits require the user to assemble the device from a set of instructions, the *HydroBot Kit* contains many small parts that distract from the fundamental concepts targeted. In addition, the reviews for this kit state that assembly takes weeks, which is not ideal in a school lab setting.



Figure 3: The Elecnor Teach Tech HydroBot Arm Kit [2]

The *Hydraulic Mini Cherry Picker*, as seen in Figure 4 is a simple hydraulic arm kit sold on Montessori Materials for about \$12 before tax. This kit is inexpensive and quick to assemble but has a fixed design and limited range of applications. Users cannot alter the design with ease for optimization, and the set up does not require the application of EGAD (ie. Reading technical engineering drawings to assemble the device.)



Figure 4: Hydraulic Mini Cherry Picker [3]

1.2 Objective

The objective of this report is to analyze the design process and evaluate the feasibility of the hoist kit. It outlines the theory behind the use of syringes as pistons and the mathematics of key topics, such as pressure, force, and fluid dynamics. In addition, it discusses the process of choosing the ideal fluid for the hoist kit. This report also details why these aspects are crucial in producing the desired result, a kit for students to better understand physics, chemistry, and EGAD principles.

1.3 Theory

The relevant theories applied include concepts in chemistry and physics introduced to students in grade twelve. The first is Equation 1: Ideal Gas Law , stating the relationship between pressure and volume when all other factors are held constant.

Equation 1: Ideal Gas Law [4]

$$P_1V_1 = P_2V_2$$

Where P_1 and V_1 are the initial pressure and volumes, and P_2 and V_2 are the final pressure and volumes. This can be used when analyzing the displacements of a syringe filled with air. Equation 2: Force related to Pressure is also necessary to fully understand the air-filled system.

Equation 2: Force related to Pressure [5]

$$\frac{F}{A} = P$$

Where F is the force on an object, P is the pressure on that object, and A is the area in contact with the pressure. The area can also be written for the circular plunger head as πr^2 , where r is the radius of the circular plunger.

Finally, in Equation 3: Volume Change related to Plunger Displacement, the change in volume is broken down into area multiplied by the change in x-position. The cross-sectional area will be a circle, which has area πr^2 , as seen above. This formula essentially shows that the change in volume based on a change in plunger displacement will be the formula for the volume of a cylinder.

Equation 3: Volume Change related to Plunger Displacement

$$\Delta V = A\Delta x = \pi r^2 \Delta x$$

Where Δx is the plunger displacement, ΔV is the change in cylinder volume, and r is the radius of the cylinder. Combining Equations 1 – 3, we can solve for the plunger displacement (Δx) in terms of force on the plunger for gases, assuming that the plunger size is the same for both sides. The result is Equation 4: Plunger Displacement related to Force, and the proof is in Appendix B.

Equation 4: Plunger Displacement related to Force

$$\Delta x = \frac{FV_1}{A(F + P_{atm}A)}$$

Where P_{atm} is atmospheric pressure. Note that for this equation, pressure must be in Pascals (Pa), Volume must be in metres cubed (m^3), force must be in Newtons (N), and displacement must be in metres (m). In this case, the force refers to the force on the end of both plungers, which should be the same due to Newton's third law, and the displacement is the added displacement of both pistons.

Equation 5 can be used to show that the rate of flow will depend on the limiting radius (which in the case of the project system is the tube):

Equation 5: Volumetric Flow Rate Equation [6]

$$Q = Av$$

Where Q is the volumetric flow rate and v is the fluid speed. Keeping fluid speed constant, the volumetric flow rate will go down if the radius also goes down, since cross-sectional area depends on radius as seen above in Equation 3: Volume Change related to Plunger Displacement.

Using Equations 1 – 3, many more equations such as Equation 4 can be derived to prove observations from the lab. However, the others are trivial, and can be found in the solutions section of the lab in Appendix A. The students are asked to prove some of these as an exercise in the lab report.

2.0 Problem Definition

The gap between rudimentary and advanced STEM courses has been widened due to virtual learning, causing students to struggle greatly. Concepts in physics and chemistry, such as fluid dynamics, are often neglected but reemerge in university. In addition, students often have trouble applying their previous knowledge to courses that require the practical application of these broad topics. This learning kit resolves discrepancies in student comprehension of physics, chemistry, and engineering design by offering an interactive experience in the classroom or at home. It lifts small objects while demonstrating the gas laws, volumetric flow rate, along with dynamics and pressure relationships.

2.1 Main Functions

The key functions of this kit are to teach students how to follow, read, and build a device from technical drawings, as well as use their device to investigate fluid properties, dynamics, and important aspects of engineering design:

2.1.1 Develop engineering design comprehension

The AutoCAD drawing is a main component of the kit. It encourages students to interpret the drawings, take measurements, and construct the hoist with the provided materials. These components introduce students to engineering drawings while allowing them to visualize how the pieces fit together. The lab teaches students building skills as it requires them to punch holes, use fasteners, and fit parts. It also involves applying fastener size and type conventions to construct the mechanism. Lastly, students will also have the opportunity to improve the mechanism by applying engineering design principles that are learned while building the hoist.

2.1.2 Establish an understanding of topics in fluid physics and chemistry

The lab requires students to visualize a mechanical system that applies fluid concepts and encourages an understanding of how pressure differs in definition from liquids to gases. It is important to establish an understanding of certain topics in fluid physics and chemistry since they are critical and reappearing topics in mechanical engineering. Some specific topics targeted in the lab include identifying the difference between hydraulic and pneumatic systems, and their applications in industry, as well as the optimal choice of system for different tasks.

2.2 Constraints and Criteria

The constraints for the design are based on safety, cost, and functionality. First, it is imperative that the hoist never falls over, particularly in its most outstretched position. Additionally, it must have an arm displacement of at least 8 cm to ensure movement is measurable and visible. Moreover, it must not be taller than 12 inches and it must be possible for the hoist to be constructed safely using simple tools. This will ensure best results in both the classroom and at home. Lastly, it must have a reasonable amount of structural integrity so that it does not collapse under its own weight.

The criteria are set with the purpose of optimizing different aspects of the hoist. The aim is to maximize both the load it can handle and the range of motion of the arm. Optimizing arm displacement will produce measurable data and better visual results for the lab. Minimizing the total cost of the kit as well as the total amount of materials required will ensure that a class set is feasible.

2.3 Safety Considerations

The hoist kit was designed with safety and clarity as a priority. This kit is designed unambiguously as it is intended for schools or at home learning in accordance with COVID-19 lockdown parameters. Hole diameters and placement are consistent and intuitive throughout the model and can be replicated with a standard sized hole-punch. Each part is secured with fasteners or paperclips to prevent the need for hot-glue guns or other dangerous means of mating. Materials, such as the corrugated cardboard, were also specifically selected to be thick enough to withstand a reasonable amount of force, but still be inexpensive and flexible enough to be cut with classroom scissors. It is important to note that the goal of this kit is not to push the bounds of complexity but rather to provide a safe and easily understood use of engineering principles.

3.0 Technical Progress

3.1 Solution and Design Iterations

To strengthen the quality of learning both in the classroom and from home, the hoist kit creates an opportunity for students to participate in an engaging activity that works well under socially distanced learning.

Some potential solutions considered before the final design are shown in Figure 5 below. Multiple different arm designs and placements were considered to determine the greatest range of motion without having to use excessively long syringes. 10 mL plastic syringes were used because they are the least expensive type of syringe that was readily available. The constraints and criteria outlined in section 2.2, such as structural integrity, were a big factor in determining the final design. The circled design in Figure 5, is the basis for our final model also shown in Figure 6.

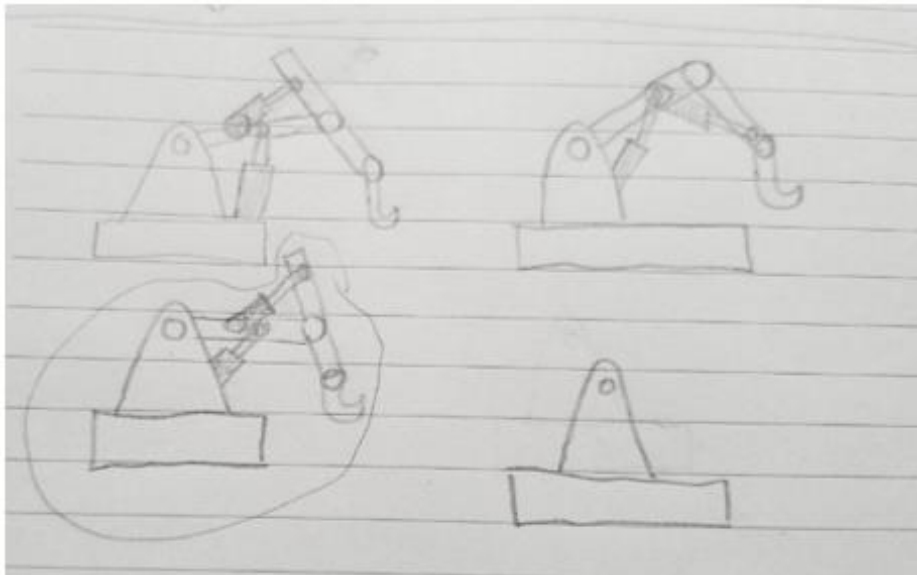
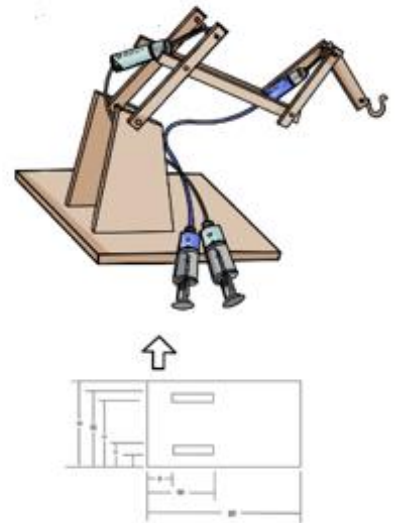

Figure 5: Iterations of the Hoist Arm Design



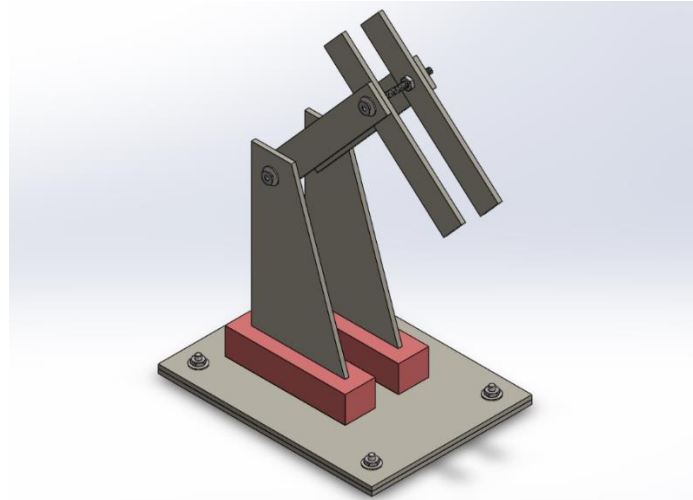

Figure 6: A SolidWorks model of the final hoist design

The process of selecting materials, parts, and specifications for the hoist kit was done meticulously. One important decision was to dimension the device in inches. The reason for this was to expose students to a common unit of measurement in industry used by machinists and contractors. Additionally, measuring in millimeters or centimeters can create a misleading impression of accuracy. This reinforces the purpose of the kit, which focuses on clarifying difficult STEM concepts through simple yet intelligent design ideas rather than further complicating these ideas. An example of this engineering judgement in action is the prefabricated base mounts of the hoist, specifically designed to provide the strongest possible base without the need for hot glue during construction. A SolidWorks model of this component, dimensioned in inches, is seen in Figure 7: SolidWorks model of the prefabricated base mounts.

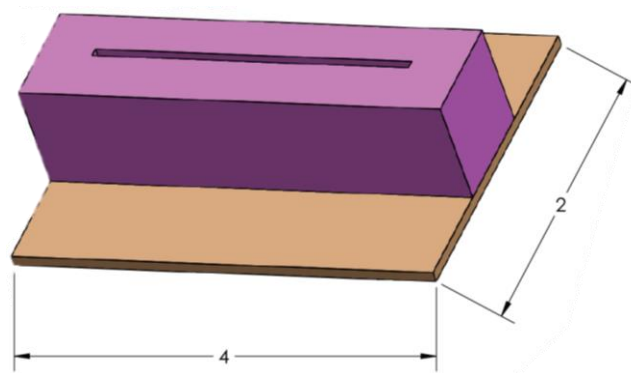

Figure 7: SolidWorks model of the prefabricated base mounts

3.2 Kit Components

The students will receive this kit from their instructor, build the hoist by reading a technical drawing, then perform a lab in which they test whether variables such as piston radius, fluid viscosity, and fluid compressibility affect other variables such as speed, force, and displacement. Finally, they will answer questions about their observations and perform mathematical and engineering analysis on their experimental results.

Components provided in the kit consist of raw materials to be measured and cut by the students. They will receive four 12"x12" corrugated cardboard sheets, 3 m of aquarium tank hose, four 10 mL syringes, four 8-32 UNC 3/4" flat socket head stove bolts, two 8-32 UNC 2" flat socket head stove bolts, six corresponding nuts, 16 small to medium sized washers, four paperclips, two prefabricated base mounts, six corresponding nuts, 16 small to medium sized washers, four paperclips, two prefabricated base mounts, six toothpicks, string, and a medium plastic hook. The kit also comes with a CAD engineering drawing, a SolidWorks model as a hint, and a work-along lab. This is pictured in Figure 8: A picture of the kit components. and Figure 9: The technical drawing of the hoist included in the kit.

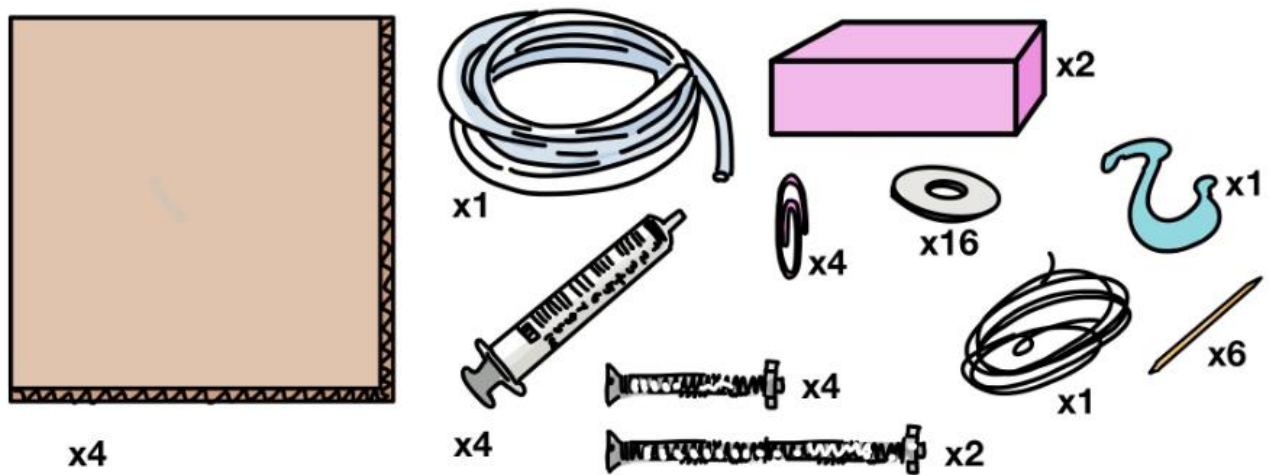

Figure 8: A picture of the kit components.

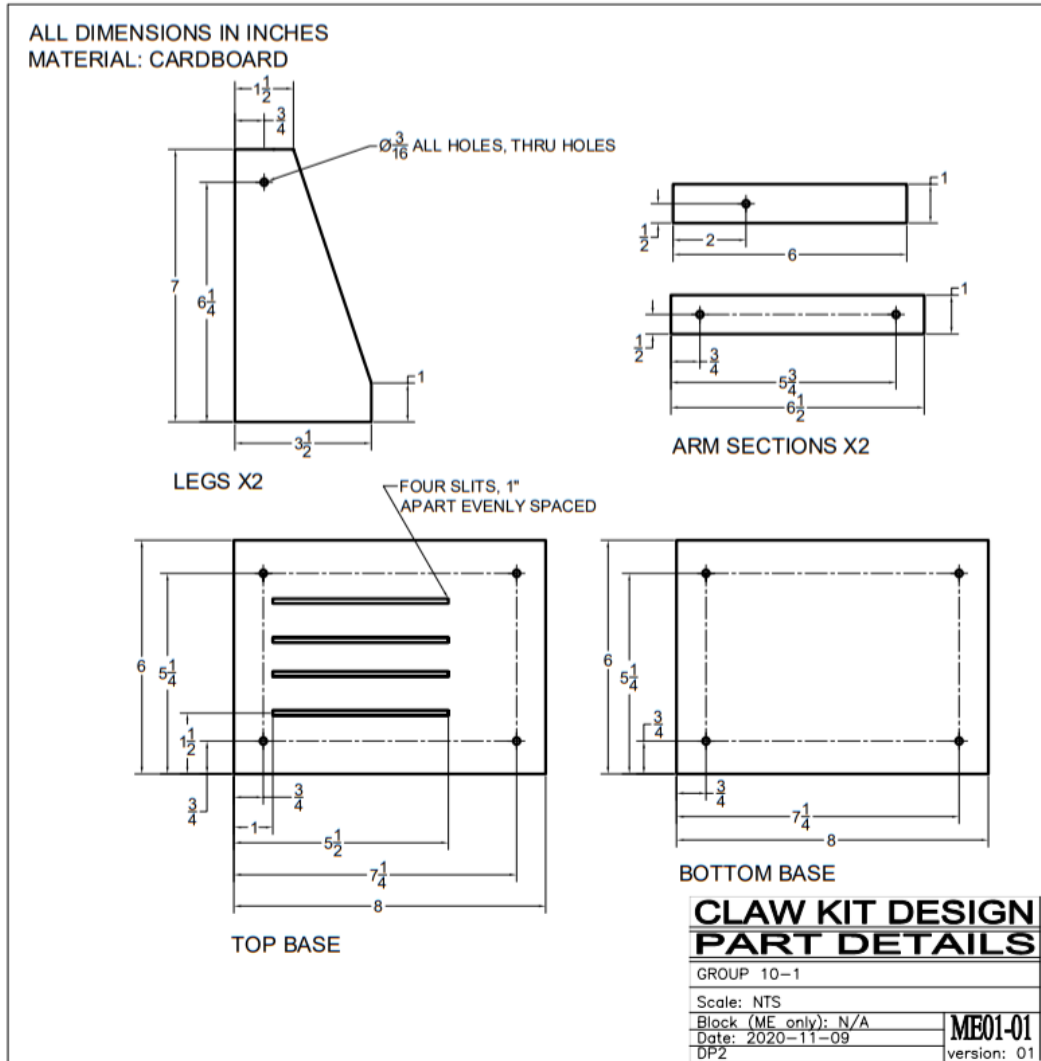

Figure 9: The technical drawing of the hoist included in the kit

3.3 Progress to Date

3.3.1 Choosing the liquids for the syringe systems

To determine the experimental properties, the dynamics of the syringes with four different fluids were tested: air, vegetable oil, ketchup, and water. Observations were made for some rudimentary theory to be confirmed, such as equal output and input displacement for liquids, and how compressibility limits the displacement in gases. When testing water, it was noted that the properties were not much different from those of the vegetable oil, so it was decided that vegetable oil would be disregarded, and a more viscous fluid would be chosen. This prompted the decision to use peanut butter.

3.3.2 Designing the hoist kit structure

The original design was planned with AutoCAD and SolidWorks. The intent was to have detachable components to avoid the need for hot glue and other complex tools. During the initial construction process, the measurements for the base, arms, and syringe placements were tested to determine the optimal dimensions for the greatest range of motion while keeping the parts simple. As seen in Figure 10, the connection between the legs of the hoist and the base of the mechanism was strategically designed as a butterfly flap that stuck into Styrofoam blocks, and then was sandwiched between two plates secured by fasteners. This provided a strong foundation for the hoist arm. The Styrofoam was quickly found to be difficult and messy to both cut and handle, so clay and foamboard were chosen as an alternative. Students will be given the prefabricated mounting blocks to assemble the bottom of the hoist in accordance with these steps shown in Figure 10: Steps of putting together the base.

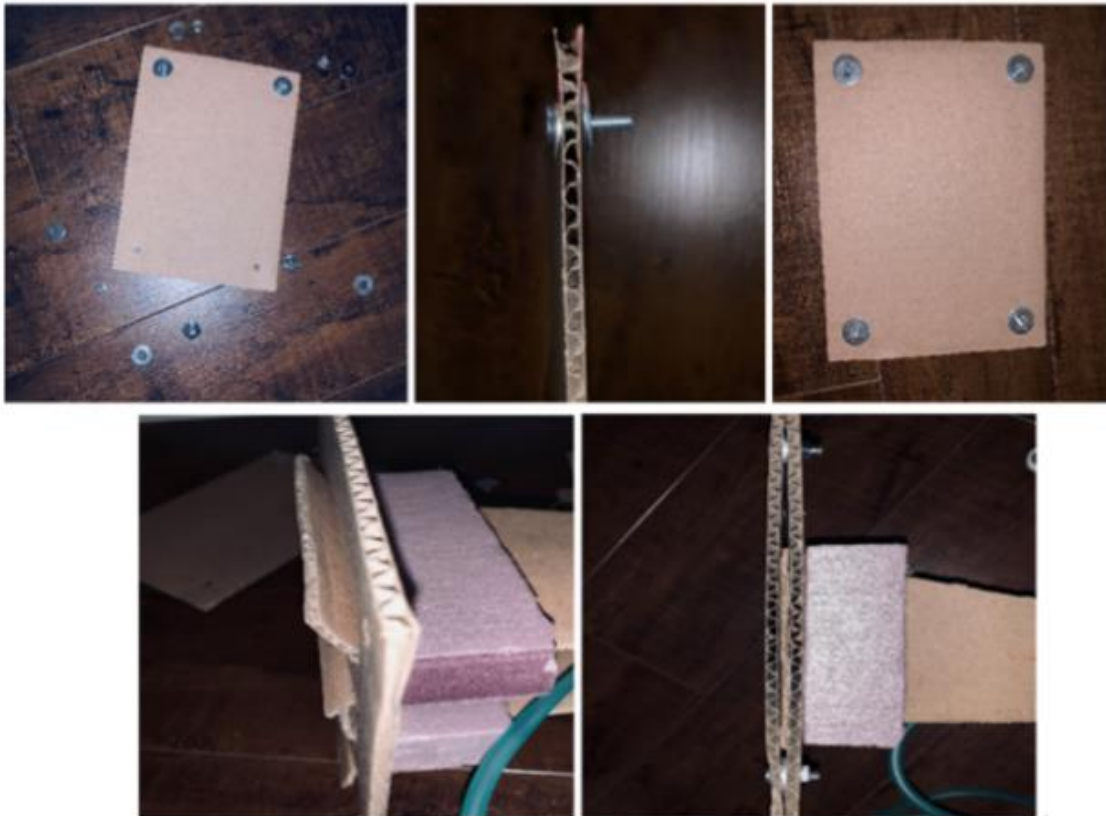

Figure 10: Steps of putting together the base

3.3.3 Implementing replaceable syringe systems

It was found to be difficult to remove the syringes in the prototypes without deconstructing most of the design, as they were originally locked in place by zip ties. This meant the pistons could not be easily swapped out with a different syringe fluid system. These issues significantly stunted the efficiency of the original prototypes, so design considerations were made to ensure the syringes could be removed and replaced on the mechanism in two ways. The peanut butter prototype used rubber bands to secure the syringes to the toothpick, while the air and ketchup prototypes implemented paperclips instead. By sliding out the toothpicks, the user could then change the size or fluid of the syringes on the same device with minimal complications. This allowed students to test more than one fluid in the mechanism without having to use separate hoists. As seen in Figure 11: The use of paperclips to fasten the syringes, the paper clips are wrapped around both the toothpick and syringe in a way that allows for easy installation and disassembly.

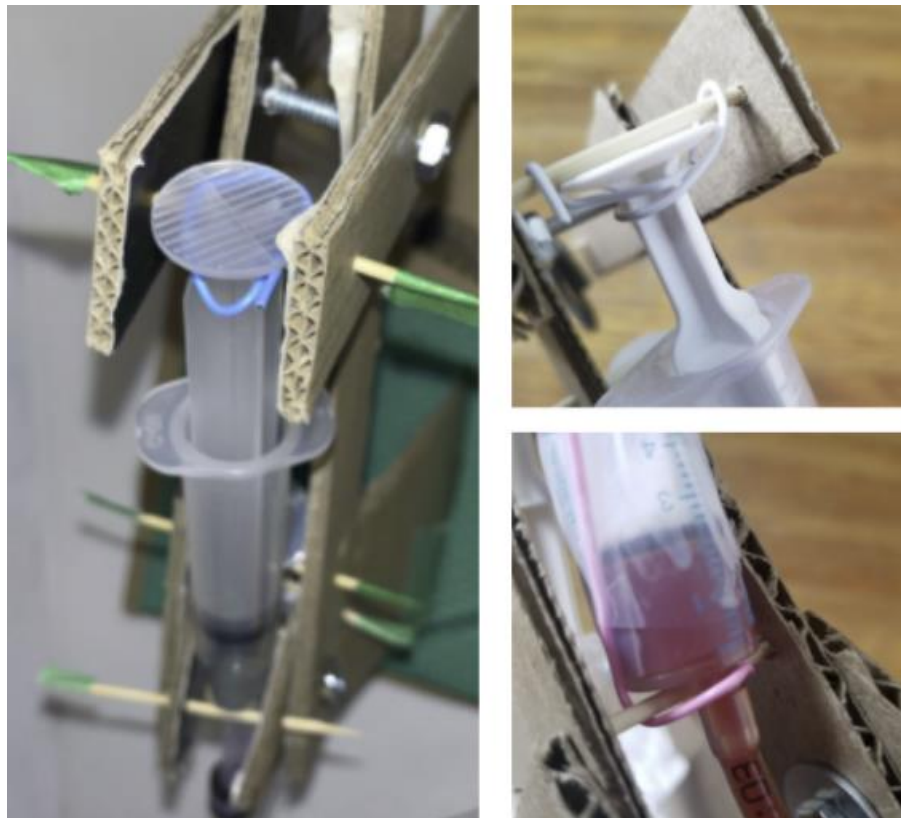

Figure 11: The use of paperclips to fasten the syringes

3.3.4 Heating the peanut butter prototype

While obtaining data with the peanut butter prototype, seen in Figure 12: Photos of the peanut butter prototype, one of the syringes snapped in half due to stress from the intense force repeatedly applied on low-grade plastic. Peanut butter's high viscosity required a strong force to move the fluid from one syringe to another. Peanut butter in the tubing also began to clump together, requiring increasingly stronger forces to be applied the longer the prototype was used. By the end of the trials, permanent deformation could be seen on all the syringes. The best solution for this prototype was to lower the viscosity of peanut butter, which was done by safely heating the entire system with a hairdryer.



Figure 12: Photos of the peanut butter prototype

3.4 Remaining Challenges

Theoretically, the four substances should each provide a different result for range of motion, speed, and ease of use. In practice, the peanut butter provided no motion unless heated up. It also proved to be messy and unsafe for a classroom setting. As mentioned previously, the peanut butter prototype's broken syringe called for a reconstructed. Alternative, low-cost substances are currently being investigated.

3.5 Data and Observations

Four prototypes were tested, each with a different substance in the syringe. This was done to ensure that the lab provides the opportunity for a variety of meaningful observations. In a classroom setting, students would be separated into groups based on the four substances so that at the end of the work period, they could compare their results. Using a hanging mass of 2 kg, a force of 19.62 N was applied to determine the retraction speed. Data was recorded in Table 1.

Table 1: A table of qualitative and quantitative data collected during prototyping.

	Test 1: Water	Test 2: Peanut Butter	Test 3: Ketchup	Test 4: Air
Retraction Speed (Applied Force = 19.62 N):	$\frac{6.0\text{cm}}{4.2\text{s}}$ = 1.4 cm/s	Not Possible	$\frac{4.25\text{ cm}}{17.5\text{ s}}$ = 0.24 cm/s	$\frac{5\text{cm}}{0.8\text{s}}$ = 6.25 cm/s
Total arm displacement:	10.0 cm	14.4 cm	14.8 cm	8.5 cm
Maximum mass lifted:	2.5 kg	0.7 kg	1.0 kg	2.36 kg
General observations:	Few issues were found with water.	Peanut Butter cooled and hardened in the system, making it impossible to fully retract the plunger.	Ketchup showed no sign of hardening after 1.5 weeks.	The compressibility of air made it impossible to fully extend the output piston using the control piston, resulting in lower speed and arm displacement measurements.

The peanut butter syringe could be retracted, but it requires two people. One person had to push on the syringe with more peanut butter, while the other person would pull on the other syringe. No measurement was included since it did not count as retraction.

3.6 Discussion and Analysis

The data from Table 1 shows that water is the ideal fluid for this mechanism as it can lift the heaviest load with a retraction speed of 1.4 cm/s when a force of 19.62 N is applied. Unlike air, it does not compress, making sure that no energy is wasted compressing the fluid in the cylinder before the output plunger moves. When an applied force was administered to the control syringe by a hanging 2 kg mass, the retraction speeds for each prototype range from 0 cm/s to 6.25 cm/s. Air was fastest, followed by water, then ketchup and peanut butter due to the increasing viscosity of the fluids. It is obvious that peanut butter is not ideal as it was much too viscous for the system, so it has been removed from the lab. Instead, honey may be a better option for future endeavors. Ketchup worked well, as it has similar properties to water, except it is more viscous. It is noticeable enough for the students to see, but not excessively difficult to work with. Although water was ideal for our system, it is not generally used in industry because it is much more susceptible to temperature changes compared to other oil and synthetic based substances. The students are prompted to realize this through one of the questions in the lab.

In terms of structure, the designs are mostly uniform, so they have similar properties in terms of maximum load and total arm range. This being said, they are still expected to be slightly different due to the different grades of materials used and the changes in design from continuous improvements. The hoist that could carry the most mass was the water-filled hoist which could hold about 2.5 kg. The hoist that held the least was the peanut-butter filled hoist which could only hold 0.7 kg. These results could be since the materials for each prototype were sourced differently. It could also be due to the technique of the person constructing the hoist.

4.0 Conclusions

4.1 Project Conclusions

The prototype stage for this project is complete and the main functions have been thoroughly examined. Using engineering drawings to communicate the designs was proven to be effective, resulting in four uniform prototypes. Several improvements were made for issues encountered throughout the design process. Bent paperclips rather than zip ties were used for securing the syringes to ensure that the syringes could be easily replaced, foam board or clay was used as the base to eliminate the mess created when handling and cutting Styrofoam, and the hoist was designed specifically so fasteners were used instead of hot glue to reduce the risk of burns.

When operating the hoists, peanut butter was found to be too viscous at room temperature and caused excess strain on the system, so it should be avoided. Water had minimal complications and optimal functions as seen in Table 1: an arm displacement of 10 cm, maximum weight of 2.5 kg lifted, and retraction speed of 1.4 cm/s when applying a force of 19.62 N. It was easy to observe the compressibility of air, and ketchup was good demonstration of a fluid with a viscosity between that of peanut butter and water.

These findings are ideal for the aim of this kit: an interactive way to see fluid mechanics in action. The different fluids work and show varying properties in terms of speed, displacement, and compressibility, which is a good demonstration and learning opportunity for students. They highlight the teachings outlined in the lab, where questions prompting analytical thinking, communication, knowledge, application, and extensions of the behavior of fluids for piston movement in the hoist kit, in industry, and other real-world scenarios.

4.2 Future Recommendations

The hoist kit has a bright future, as it has been proven to be feasible and structurally sound. However, commercial viability and student interest remain to be determined. It is also possible to construct a hoist using the materials outlined in section 3.2, and the design is strong enough to hold from 0.7 kg to 2.5 kg of weight. In addition, all the prototypes were uniform, so it is fit for large groups of students to follow for both the classroom and remote learning. The next steps, if this project were to be continued, would be to source materials, find manufacturing facilities, and begin trials with select schools before releasing to the public.

References

- [1] J. K. J. Z. J. E. A. M. N. L. B. Kenneth R. Koedinger, "Learning is Not a Spectator Sport: Doing is Better than Watching for Learning from a MOOC," Carnegie Mellon University, Vancouver, 2015.
- [2] "Elenco Teach Tech HydroBot Arm Kit," Amazon, 23 July 2019. [Online]. Available: https://www.amazon.ca/Elenco-Teach-HydroBot-Hydraulic-Educational/dp/B07NVFGH2X/ref=asc_df_B07NVFGH2X/?tag=googleshopc0c-20&linkCode=df0&hvadid=459571610149&hvpos=&hvnetw=g&hvrand=13027852788535777080&hvpone=&hvptwo=&hvqmt=&hvdev=c&hvdvcmdl=&hvlocint=&hvl. [Accessed 18 November 2020].
- [3] "Hydraulic Mini Cherry Picker," E&O Montessori, [Online]. Available: <https://www.montessorimaterials.com/products/hydraulic-mini-cherry-picker>. [Accessed 18 November 2020].
- [4] D. R. Nave, "Ideal Gas Law," HyperPhysics, [Online]. Available: <http://hyperphysics.phy-astr.gsu.edu/hbase/Kinetic/idegas.html>. [Accessed 05 12 2020].
- [5] D. R. Nave, "Pressure," HyperPhysics, [Online]. Available: <http://hyperphysics.phy-astr.gsu.edu/hbase/press.html>. [Accessed 05 12 2020].
- [6] "What is Volume Flow Rate?," Khan Academy, [Online]. Available: <https://www.khanacademy.org/science/physics/fluids/fluid-dynamics/a/what-is-volume-flow-rate>. [Accessed 5 November 2020].

Appendix

Appendix A – Hoist Lab Handout

UNIVERSITY OF
Waterloo



Department of Mechanical and Mechatronics Engineering

Hydraulic Pneumatic Hoist Kit Lab

Prepared By:

Joyce Chen | Emily Folk | Remy Lambert | Lance Pharand

Department of Mechanical and Mechatronics Engineering

University of Waterloo

200 University Ave W.

Waterloo, Ontario, N2L 3G1

17 November 2020

APPLICABLE COURSES: CHE 102, PHYS 115, SCH4U, SPH4U

OBJECTIVE:

In this lab you will learn about the mathematical relationship between pressure and force in the scope of hydraulic and pneumatic cylinders. You will also discover how various liquids and their respective viscosities affect a mechanism's performance. You will be expected to understand the importance of precision in design and construction. Most importantly, you will apply engineering design skills to build, improve, and analyze a fundamental mechanical idea.

MATERIALS: (Most are provided)

- 12x12 corrugated cardboard sheets x4
- 3m aquarium tank hose
- Ruler, caliper, or tape measure
- Single hole punch
- 10 mL syringes x2
- 8-32 UNC 3/4" Flat socket head stove bolts x4
- 8-32 UNC 2" Flat socket head stove bolts x2
- Washers x16
- Nuts x8
- Prefabricated foam base x2
- Exacto knife
- Duct tape
- Zip ties
- Safety glasses
- Medium plastic hook and string
- Play Doh or clay
- A light object to lift

SAFETY BRIEFING

Using Exacto knives: Always cut away from yourself, never towards. Adjust your body position and workspace if this is not possible.

Safety glasses: Wear safety goggles to prevent any eye injuries while working with small or sharp components.

Punching toothpick holes: Punch holes away from yourself and keep your fingers out of the way.

FOLLOW INSTRUCTIONS CAREFULLY!

KIT TECHNICAL DRAWING

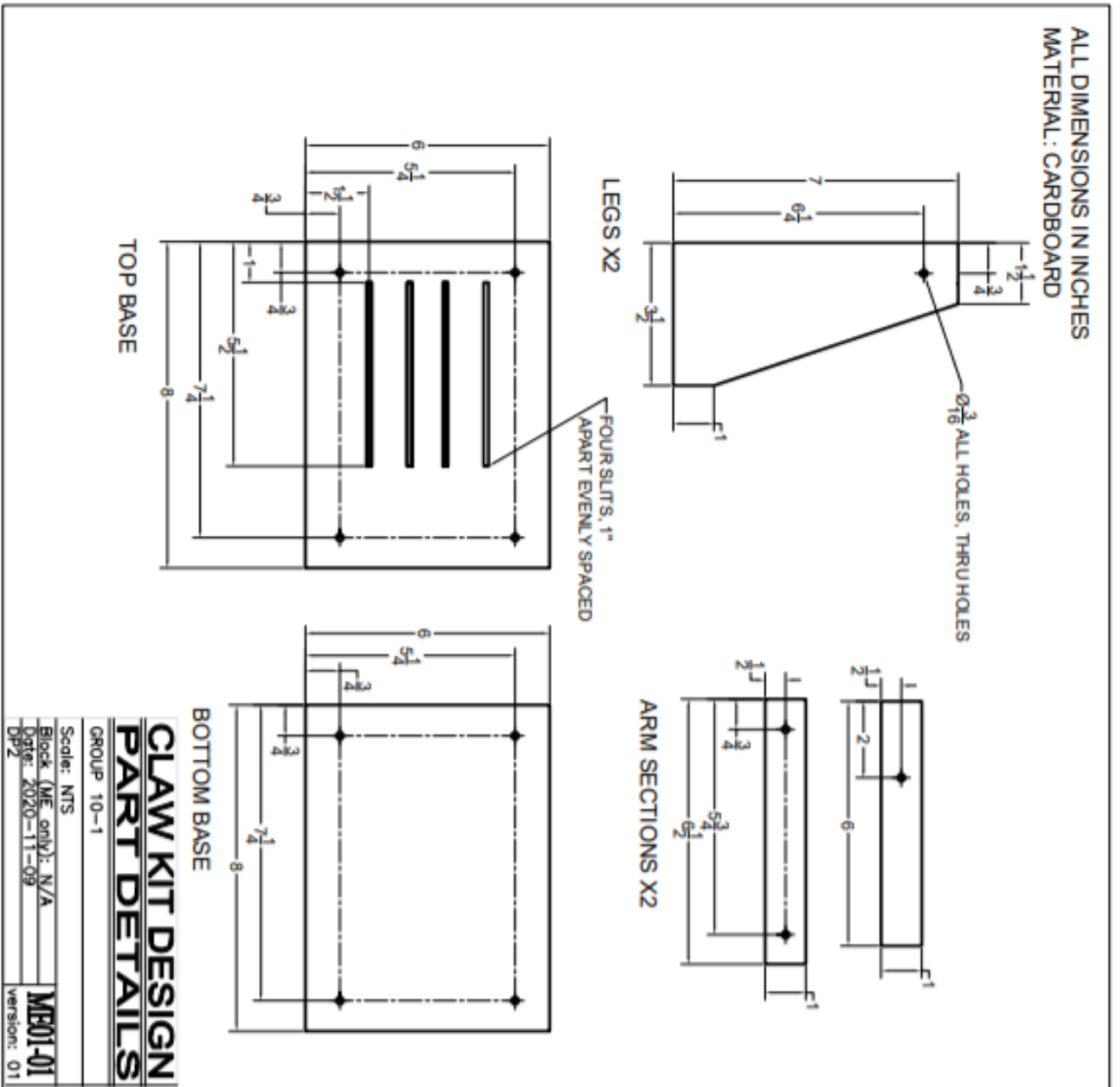

HYDRAULIC PNEUMATIC HOIST BUILDING INSTRUCTIONS

1. Measure out the cuts and use a pencil to draw the outlines of the shapes you will need onto the sheet of cardboard, using the technical drawing for measurements. Once you have drawn the outline, use the edges as a reference to identify the center of the holes.
2. Repeat step 1 to double check all your measurements. Remember: *Measure twice, cut once.*
3. Cut pieces of cardboard to the correct shape using the lines you drew as a guide. An exacto knife or sharp scissors can be used to do this, but always make sure that you are cutting **away** from yourself, and that your fingers are **out of the way!**
4. Use a hole punch to punch out the holes at the spots that you marked in step one. Again, keep your fingers out of the way.
5. Tuck the feet of the prefabricated base mounts through the slits in the bottom plate. Wedge the upright supports through the slit in the foam.
6. Use four 8-32 UNC $\frac{3}{4}$ " bolts to secure the upper plate to the lower plate. Ensure the countersunk sits flush with the floor and direct the length of the bolt in the upward direction. Add a washer underneath each bolt head and on the top of the plate underneath each nut.
7. Use one 8-32 UNC 2" bolt to attach the primary arm segment to the upper supports. Once again, place washers in between stress points.
8. Use the second 8-32 UNC 2" bolt to attach the secondary arm segment to the primary arm segments. Place washers accordingly.
9. Poke toothpicks in the place you would like to mount the syringes. Aim to have one on the upright supports and one on the primary arm segments
10. Poke a toothpick between the secondary arm segments to add a hook
11. Fill one syringe with just over 9mL of a substance (water, air, ketchup, honey) and the other with about 1mL. Connect the nozzles of the syringe to about 20 inches of the fish tank tubing. Fill another with about 7mL and connect it to one with about 2mL.

12. Mount the lowest-sitting syringe FIRST using a paperclip as shown below. This will avoid any view obstruction when you are adding the second pair of syringes. The syringe with the higher volume of liquid should be connected to the syringe mounted between the upright supports.
13. Mount the syringe filled with 2 mL to the higher toothpick axel and ensure it is connected to the syringe filled with 7mL. The attached syringes will serve as “control buttons” for the two swivel spots so they can be left unmounted.



14. Add the hook to the last free axel and test the hoist! Pushing down on the lower control syringe will move the mechanism up about the primary pivot point. Pulling it back up will lower it. Pushing down on the upper control syringe will move the mechanism about the secondary pivot point. Once again, pulling it back will reverse the motion. Is it able to lift a small object attached to the hook?

HYDRAULIC PNEUMATIC HOIST LAB INSTRUCTIONS

You will need:

- A ruler (and caliper if you have one),
- A piece of paper and pencil to record measurements,
- A stopwatch,
- Your brain.

If this lab is being done in a school setting, it is best to work in groups of 2-3, with each person having a different fluid in their syringes. If this is not possible, the lab can be done twice, using air the first time and a liquid the second time.

1. First, the displacement will be measured. Use your ruler to measure the current displacement of each cylinder, measuring from the zero marking on the syringe to the closest part of the piston. Also use your ruler (or caliper, if you have one) to measure the *inner* diameter of each piston, as well as the *inner* diameter of your rubber tube. Then, press down on one syringe a certain distance, and measure the new displacement on that syringe and the opposite syringe. Subtract the initial measurement from the final measurement to get the change in displacement.
2. Next, speed will be measured. What you are going to do is press one output plunger until it is at the bottom, then time how long it takes for the output plunger to be fully extended when you press the control plunger down to the bottom. In order for your comparisons between different fluids to be accurate, you will need to use a relatively consistent force, which can be achieved by pressing as hard as you can with one hand, but **don't press so hard as to break a component, or lose control**. Now perform the same experiment except you will measure the time it takes for the output plunger to fully retract when you extend the control plunger.
3. Now total arm displacement will be measured. Take a piece of paper and position a corner so that it sits against the foam supports and the base of your hoist. Retract the arm as much as possible (make the endpoint of the arm as close as possible to the corner where you just put the corner of your paper), and you should be able to use the toothpick on the end of the arm to punch a hole in the paper. Next, extend the arm as much as

possible (make the endpoint as far as possible from the first point), and punch another hole in the paper using the same toothpick. Finally, lay your paper flat and measure the distance between the two holes poked in the paper.

If you are doing this lab alone, it is at this point that you will repeat steps 1 - 3 with a new fluid.

4. Finally, force will be measured. First, feel it for yourself by holding both the control and output syringe, and press down on each end. Jot down any observations. Use something that you know the weight of (like coins) and put them into a small bag. Attach this bag to a string that you can hook onto the end of the arm. Continue to add coins until the design fails (it cannot support the weight by normal function). If your design falls over before it fails, you may want to extend the piston controlling the secondary arm segment, which will bring the tip of the arm closer to the upper supports, and should make the design less likely to fall over.

HYDRAULIC PNEUMATIC HOIST LAB QUESTIONS

Base Formulas: $P_1V_1 = P_2V_2$

$$F/A = P$$

$$Q = Av$$

$$V = A\Delta x$$

P -> Pressure in Pascals

V -> Volume in m^3

F -> Force in Newtons

A -> Cross sectional Area in m^2

Q -> Volumetric flow rate in m^3/s

v -> Fluid speed in m/s

Δx -> Displacement in metres

Communication:

1. What did you notice about the displacement of the control plunger relative to the output plunger? Was there a difference when using a gas versus a liquid?
2. Compare your speed results with a classmate (or compare your results from the two tests), were they very different? If they were different, what do you think caused this?
3. When you measured force, what did you notice? What happened to one hand if you increased the force on the other? Were you able to make both ends go down? Compare your responses when using a gas versus a liquid.

Knowledge:

Don't forget significant figures and units!

4. Calculate the pressure inside a cylinder with radius 2.5 cm if the force exerted on each plunger is 10.0 N. (Hint: don't forget to account for the force exerted by the outside pressure!)
5. Compute the volumetric flow rate (in m^3/s) for a cylinder of radius 3.0 cm and fluid speed of 1.0 km/h.
6. Calculate the change in volumetric flow rate if the flow velocity is kept constant while the radius changes from 5.0 cm to 3.0 cm.

7. Consider a system where the output cylinder has a radius of 3.0 cm and the control cylinder has a radius of 2.0 cm. Compute the net force on each plunger if the pressure inside the system at SATP is 1.5 atm.
8. What is the pressure inside a system of two pistons both with length 10.0 cm and with radii 2.50 cm and 3.00 cm respectively, if the plunger with radius 3.00 cm is pressed down 8.00 cm while the other is kept stationary?

Thinking:

Using the three base formulas above certain observations from the lab can be proved. For example, we can prove that the force that the output syringe puts on the arm will be the same as the force that you put on the control plunger:

$$P_1 = P_2 \rightarrow F_1 A_1 = F_2 A_2 \rightarrow F_1 = F_2$$

We start with the fact that the pressure on the output plunger will be the same as the pressure on the input pressure (due to basic gas laws), and then we substitute pressure for Force over area, which is given in the base formulas above. Finally, assuming the radii of the input and output cylinder are the same, we know that they will have the same cross-sectional area, and can divide out the area, simplifying the expression and proving the initial statement.

Using similar strategies, prove the following:

9. For liquids in cylinders of equal radius, the magnitude of the input displacement will be the same as the magnitude output displacement.
10. For syringes of two different radii containing liquid, the ratio between the radii is equal to the ratio between the speeds.
11. Derive an equation for the change in displacement of the control plunger for gases when a force is applied to it without the output plunger moving.

Application:

12. What is one way that you could make a pneumatic able to take a greater amount of force before compressing the gas inside the cylinder?
13. Is water the most practical choice of fluid for a hydraulic system? Describe the implications of using water in the brake lines of an automobile or another similar situation. Connect this to your knowledge of physical properties. Finally, suggest an even better fluid alternative.
14. What is the benefit of mating surfaces with fasteners, particularly countersunk bolts in this case? What is the purpose of the washers on this particular design? List another mechanism of your choice where a washer might be a critical component.

Extending:

15. Identify at least 3 short-comings with the mechanism's design and ways to mitigate these issues. How could you increase the hoist's speed, range of motion, or efficiency? How could you redesign the mechanism to carry heavier items?
16. Identify the difference between hydraulic and pneumatic systems. Give at least one example of each in industry and state why it is the better option for the task. Motivate your answer with physics, math, and chemistry principles.

ANSWER KEY

1. For liquids displacement should be equal, for gasses it should not be equal. This is because liquids are virtually incompressible under normal circumstances, but gases will compress when a force is applied.
2. They should be different for each fluid. More viscous fluids like honey and ketchup should be much slower than less viscous fluids like air and water.
3. Force should be the same on both ends, for liquids because they are incompressible, and for gases because the pressure on each plunger will be equal (as long as the radius of each cylinder is the same). See the example derivation in Thinking.
4. 110 kPa
5. $7.9 \times 10^{-4} \text{ m}^3/\text{s}$

6. $-0.0016\pi v \text{ m}^3/\text{s}$
7. 140 N, 64 N
8. 106 kPa
9. $V_1 = V_2$

$$V_1 + A_1 \Delta x_1 = V_2 - A_2 \Delta x_2$$

$$x_1 = -x_2$$

$$|x_1| = |x_2|$$

10. $V_1 = V_2$

$$V_1 + A_1 \Delta x_1 = V_2 - A_2 \Delta x_2$$

$$x_1 \pi r_1^2 = x_2 \pi r_2^2$$

$$x_1 r_1^2 = x_2 r_2^2$$

$$x_1 r_1^2 / t = x_2 r_2^2 / t$$

$$r_1^2 / r_2^2 = v_1 / v_2$$

11. $P_1 V_1 = P_2 V_2$

$$P_{\text{atm}} V_1 = (FA + P_{\text{atm}})(V_1 - A \Delta x)$$

$$0 = FV_1 A_1 - F \Delta x - P_{\text{atm}} A \Delta x$$

$$\Delta x = FV_1 A / (F + P_{\text{atm}} A)$$

12. Pressurize the cylinder - gas becomes harder to compress the more it is pressurized, so although it would require more force to move, there would be less wasted motion.
13. Water is very susceptible to temperature changes - it freezes at 0°C and boils at 100°C . This is a very small range, and freezing especially can really damage equipment since ice takes up more volume than water. This means that oil and synthetic based fluids are generally used for brakes and other industry applications because they have greater liquid temperatures ranges.

14. Bolts can be easily removed and replaced, and the washers spread the clamping force of the nuts over a greater area, making the structure less likely to get damaged around the already weak holes.
15. Answers may vary. Examples: Use tubes with a greater radius to increase speed, change position or length of cylinders to change range of motion, use stronger material and a control piston with a smaller radius than the output piston to lift heavier objects.
16. Hydraulic systems are generally better because liquids are incompressible and their volume won't change with temperature, compared to gases in pneumatic systems. Air might be better in the food industry however because it's cleaner, and also could be used where leaks must not cause it to totally fail. Leaks in a hydraulic system will render it useless but leaks in a pneumatic system are not fatal - the mechanism can still be used albeit at lower performance.

3D MODEL HINT... ONLY USE IF STUCK!

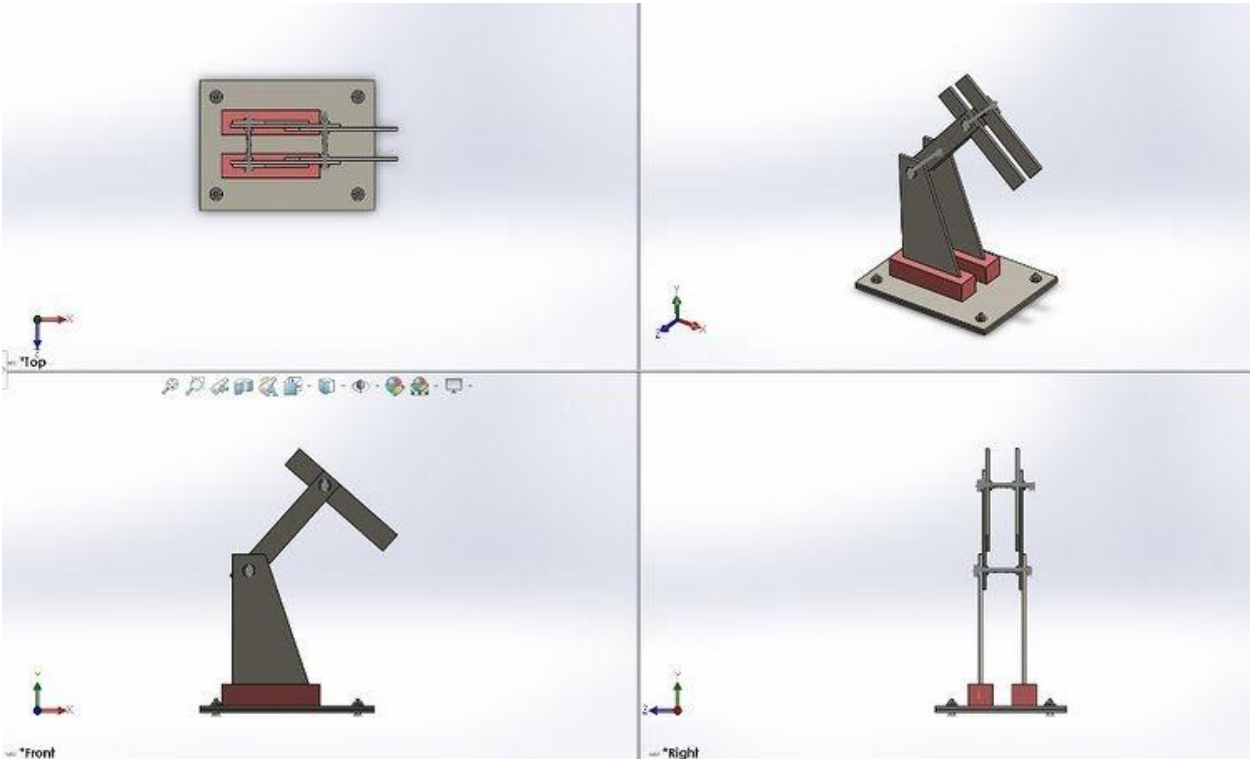

Appendix B: Equation Derivations

Derivation of Equation 4: Plunger Displacement related to Force

We begin with Equation 1: Ideal Gas Law . Line two is the most important, as several key substitutions are made, beginning with substituting P_{atm} , atmospheric pressure for P_1 . This is because the initial pressure in the cylinder is going to be atmospheric pressure. Next, P_2 is substituted for Equation 2: Force related to Pressure added to P_{atm} . This is because the pressure after the plunger has moved will be the original pressure plus the pressure that comes from compressing the air, which can be written as Force over A as per Equation 2: Force related to Pressure . Finally, V_2 is rewritten as the initial volume, V_1 subtract the change in volume, which can be written as A multiplied by Δx as per Equation 3: Volume Change related to Plunger Displacement. The rest of the proof is rearranging the equation to solve for Δx , and what is left is Equation 4: Plunger Displacement related to Force.

$$P_1 V_1 = P_2 V_2$$

$$P_{atm} V_1 = \left(\frac{F}{A} + P_{atm}\right)(V_1 - A\Delta x)$$

$$0 = \frac{FV_1}{A_1} - F\Delta x - P_{atm}A\Delta x$$

$$\Delta x = \frac{FV_1}{A(F + P_{atm}A)}$$